



[www.lifetime.com](http://www.lifetime.com)

Figure 1: Fold 25½" x 30" paper in half length wise.  
Make folded sheet 25½" x 15"

Figure 2: Mark paper ½" at the top and 3" at the bottom with fold on the left side.  
Draw line from top to bottom of each mark.

Figure 3: Fold left flap along the line drawn.  
Place a piece of clear tape along the middle of the two flaps to create your spine.  
Press firmly to adhere tape then cut excess to the edge of the paper.

Figure 4: Lay a 25" wooden dowel to each outer corner of the flaps as shown below.  
Lightly glue then place a piece of clear tape over the dowel, press firmly to adhere.  
Cut tape excess to the edge of the paper.

Figure 5: Flip kite so the top is facing down.  
Punch a hole 1/3 of the way down from the top tip of the kite on the middle flap.  
Cut 6 to 10 feet of ribbon or light weight string then tie it through the hole.  
Twist knot tied in ribbon/string to the bottom of the flap so the it will pull evenly when flying.  
Secure with tape.

Figure 6: Tape other end of ribbon/string to a cardboard roll.  
Wind loose ribbon/string around roll to keep it from getting tangled before flight.

### PREPARE FOR FLIGHT AND ENJOY!

\*You may use any sturdy material of your choice.

For added appearance choose bright, contrasting colors you can even add decorative elements to your kite.

Figure 1

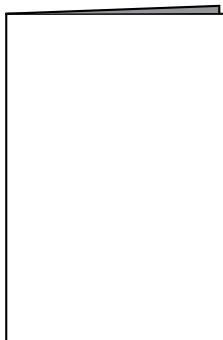
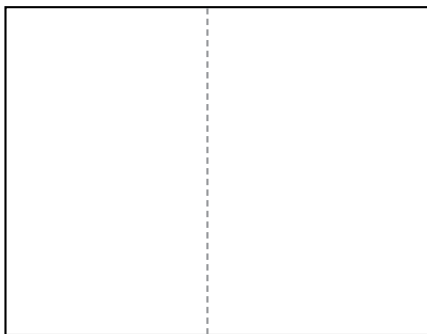

Figure 2

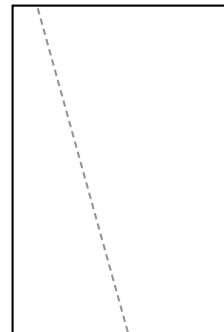

Figure 3

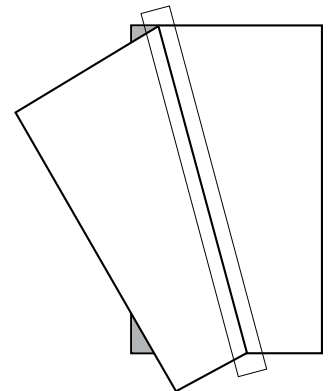

Figure 4

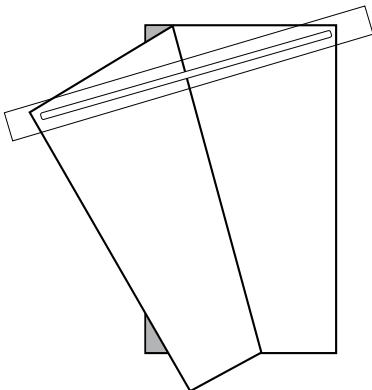

Figure 5

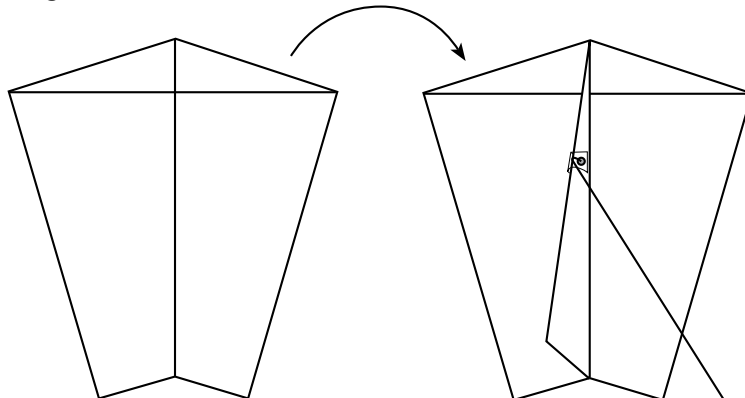

Figure 6